



PoolStar Products

Instruction Manual for SP2526C LED Underwater Light

Manufacturer: O'Ryan Industries, Inc.

12711 NE 95th Street

Vancouver, Wa. 98682

Telephone:

1(800) 426-4311- 1(360) 892-0447

Website: <http://www.oryanindustries.com>



IMPORTANT: This manual includes essential information on the safety measures to be implemented for installation and start-up. Therefore, the installer, as well as the user, must read these instructions before beginning installation and start-up.

Technical Specification

Standard input voltage: 12V AC/DC (Range: 12~18VAC or DC)

Standard input watt:

RGB / White

5W /7W (45 Normal LED)

Use life: 60,000 hours

16 programs with Synchronization capability

PoolStar Products

Dimensions:

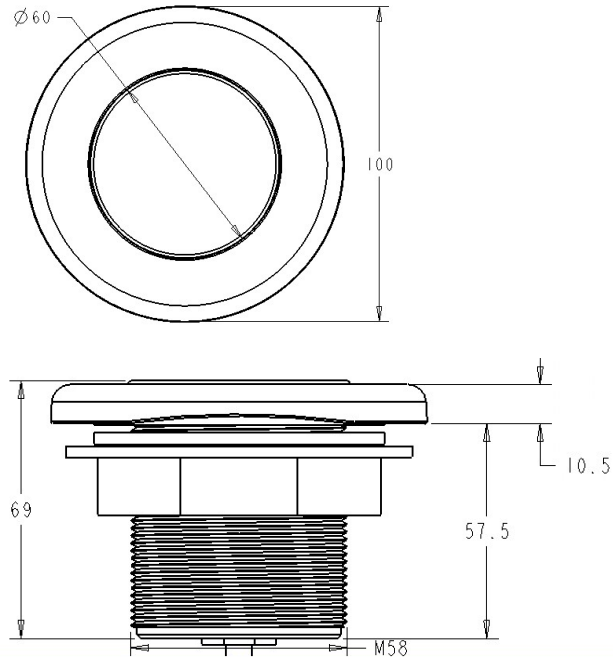

Warranty

The manufacturer warrants this LED underwater lights against defects in materials and workmanship for a period of one year from the date of purchase. This warranty does not cover the fixture becoming damaged due to misuse, accidental damaged, improper handling and/or installation and specifically excludes liability for direct, incidental or consequential damages.

Defects in materials and workmanship are exclusive of the following:

- The light has small air bulbs inside the resin on the back side.

Maintenance/Installation

There is no maintenance required for this lamp – it is designed to be used only once, meaning that replacement is necessary if it becomes defective (repairing is impossible). Before any handling, ensure that there is NO voltage supplied to the lamp. To replace, unfasten the lamp from the bracket. Ensure the new lamp is of the same model and characteristics as the one being replaced.

Start-up

- The lamp should only operate underwater while secured to the vertical walls of the pool. **Never switch on the lamp if it is not underwater.**
- In case of colored lamps, 16 pre-programmed effects and combinations may be selected using

the on/off switch of your pool lights. Just switch off and on within 2 seconds.

- If the light is powered off for more than 20 seconds, it will keep the last program when it is turned on again.
- To achieve synchronization, confirm all lamps are installed correctly on the same switch, after they are powered off for more than 20 seconds, switch on and off continuously three times, and then finally turn them on again. They will all go to program 5. Now you can select a program for them by switch off and on within 8 seconds.
- Alternatively, we recommend using our optional controller (with built-in safety transformer) which comes with (a) remote control for easy operation and (b) auxiliary connection of 24V for operation of any other electrical item.

Safety Warnings

The persons who are in charge of installation should have the required qualifications for this type of work.

- Avoid making contact with the electric voltage.
- Comply with the current standards regarding accident prevention.
- IEC 364-7-702 standards must be observed: WIRING IN BUILDINGS, SPECIAL WIRING, SWIMMING POOLS.
- Replacement must be performed with the lamp disconnected from the electric power system.

Packing Contents

The following items are included inside the box:

Lamp Assembly x 1
Plastic Nut x 1
Rubber Ring x 3

Instruction & Use

This is a high technology electronic controlled light based on LED's in three colors: red, green and blue. These three base colors together can produce many other colors to create the perfect atmosphere in the pool. Any of the 16 pre-programmed effects can be selected with the on/off switch of your pool lights. The LED's can also be warm white only or natural white only. The

LED's are driven by constant current. The technology of True PWM is adopted on the lights.

High temperature protection causes the LED's to be protected when the internal temperature reaches a high level. All this technology guarantees long working life of the LED lamps. The lights must be used / operated while fully submerged underwater **only**.

- This lamp is designed to be fixed in new pools and/or pools with existing surface mounted lamps that need replacement.
- This lamp is designed to be used only once. Should it become defective, repair is impossible, and replacement is necessary.
- The manufacturer is not responsible in any circumstances for assembly, installation or start-up of any electric components which have been inserted or handled at locations other than its own premises.

16 programs of RGB colors

1. White: sun white
2. Red: one color red
3. Green: one color green
4. Blue: one color blue
5. Green-blue: fixed color green/blue
6. Red-green: fixed color red/green
7. Blue-red: fixed color blue-red
8. Evening sea: slow animation red/blue
9. Evening rivers: slow animation red/green
10. Riviera: slow animation green/blue
11. White: neutral white
12. Rainbow: slow animation blue/red/green
13. River of colors: program 12, followed by program 15
14. Disco: fast animation
15. Four seasons: slow animation in red/blue/green/violet
16. Party: fast animation

Installation

All lamps should be placed on the wall of the pool below the water surface, in areas that are easily accessible from the upper edge of the pool.

- All lamps should be installed on the same transformer and switch.
- The lights can be installed for both concrete pools and fiber pools.
- The lights fit into standard pool 2" fittings.
- The lamp is supplied with cable of 7ft., 12ft., 20ft., 30ft., 50ft. or 65ft. according to the need of the user, making it possible to install multiple lamps connected to a single junction box.

The light can be fixed on concrete or stone wall pools, thin wall pools, fiberglass wall pools, metal wall pools, or wooden wall pools with liner.
It can be threaded into the 2" female-thread conduit/pipe

For thin wall pools, polyester, fiberglass, metal or wooden wall pools with liner:

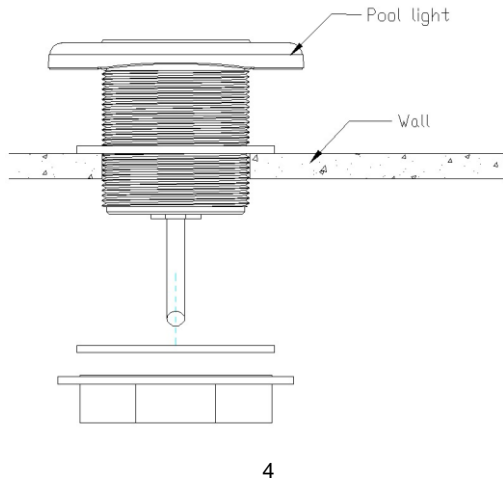

4

For concrete or stone wall pools, liner and mosaic:
Thread the light into the interred conduit

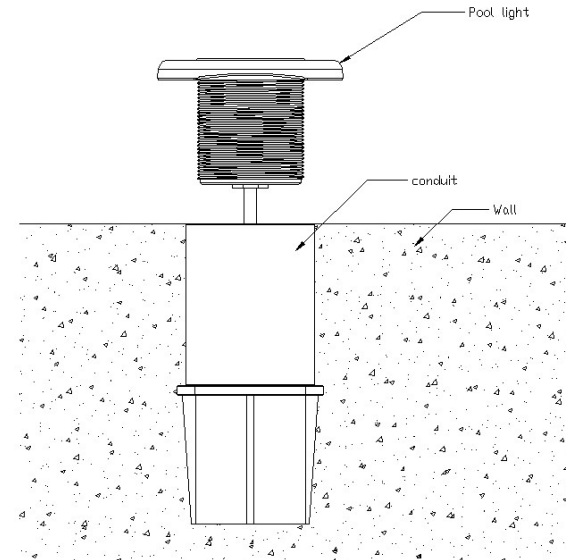

The below drawing shows how to connect the cable from the lamp to the power source.

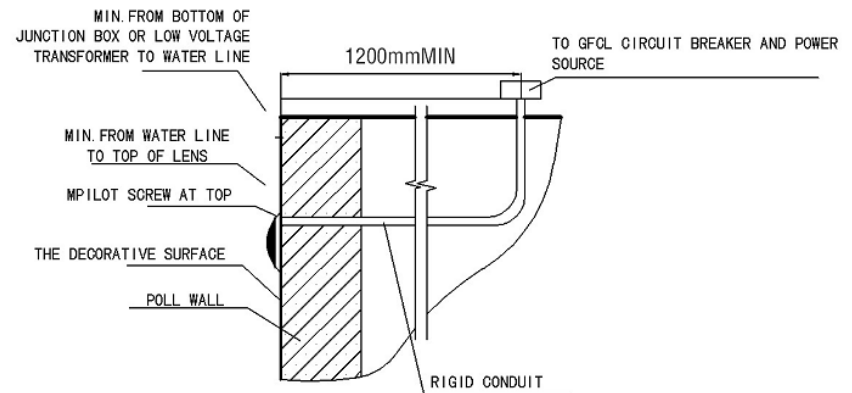

Installation Diagram